

Bilevel

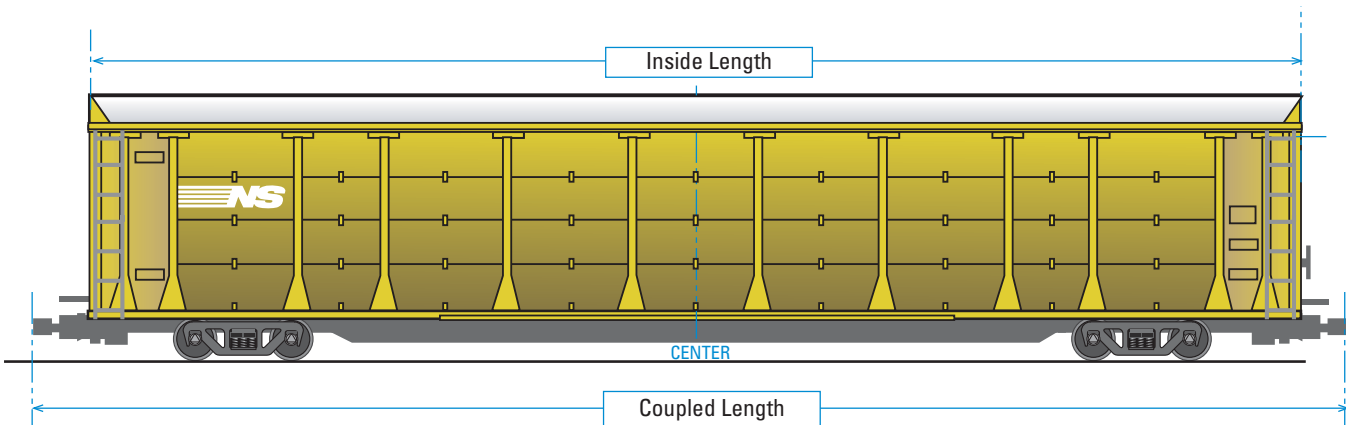

DESCRIPTIONS

Bilevel Ranges

Load Limit 40,001 lbs of vehicles symmetrically loaded on each deck

Number of Vehicles Per Rail Car 5 vehicles up to 17' 6" long/deck 6 vehicles up to 14' 6" long/deck

Bottom Deck Clearance ("A" Deck) 7' 0" to 7' 7" ; 7' 3" standard
Top Deck Clearance ("B" Deck) 7' 7" to 8' 0" ; 7' 11" standard

Loadable Length..... 89' 4" standard
Loadable Width 9' 0" standard
Overall Height..... 19' 0" ATR standard

Underframe Hydraulic draft gear

Special Features Wheel chocks, tiedown chains

Major Commodities Vehicles up to nominal 7' 1" height

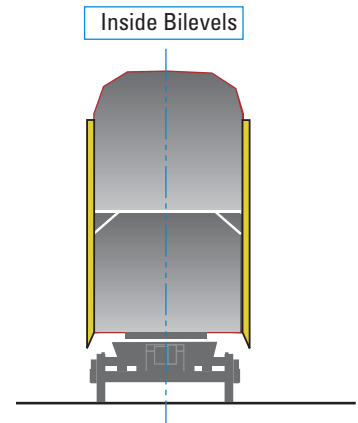
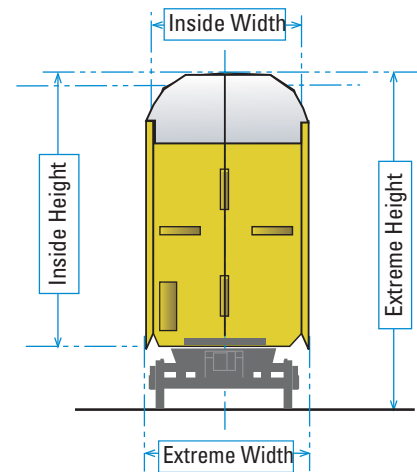

Actual dimensions may vary.